

NEW

POLARIS Laser Scanner

New Compact, Powerful,
Scanning Technology from
Teledyne Optech

The **Polaris Terrestrial Laser Scanner (TLS)** delivers accurate, precise data faster than ever before, bridging the gap between small, light-weight, short-range sensors and large, long-range, pulsed time-of-flight scanners. Built with surveyors in mind, the Polaris has a user-friendly on-board operator interface with menu-driven operations for quickly collecting and referencing data.

With an integrated high-resolution camera, inclinometers, a compass, a L1 GNSS receiver, and weather-proof housing, the Polaris can be deployed in many environments and orientations. The Polaris leads the market in price versus performance, starting at a price that rivals short-range scanners while outperforming most long-range scanners. With accelerated performance and all the built-in features surveyors need, a single Polaris executes more applications than ever before. Whether on a tripod, vehicle, or moving platform, the outstanding performance of the Polaris makes it the most versatile terrestrial laser scanner on the market.



APPLICATIONS

- » Civil Engineering
- » Construction
- » Transportation
- » Heritage
- » Mining
- » Forensics
- » Forestry
- » Scientific Research



FEATURES

- » Long-range capability
- » High-speed data acquisition
- » 100% scanner efficiency
- » Wide, selectable field of view
- » Internal data storage
- » Internal camera
- » External camera option
- » Weather-proof housing
- » Automatic target recognition
- » User-friendly workflow
- » Automatic target-free registration
- » Project planner
- » Multiple lidar returns
- » Tilt compensation
- » L1 GNSS receiver
- » Compass
- » Laser plummet
- » Easy upgrade

The Polaris Family...

Versatile Capability for Diverse Data Capture Applications



Polaris HD Single, fast data collection rate

Ideal for short-range (up to 250 m) applications where documentation and verification are required.

System Performance

	Polaris HD
Laser repetition rate (peak and effective, kHz)	500
Max range capability @90% reflectivity (m)	250
Max range capability @20% reflectivity (m)	125

Polaris ER 2 data collection rates for more applications

Two programmable data collection rates and a range capability increased to 750 m plus options such as external cameras and GNSS.

System Performance

	Polaris ER	
Laser repetition rate (peak and effective, kHz)	200	500
Max range capability @90% reflectivity (m)	750	250
Max range capability @20% reflectivity (m)	400	125

Polaris LR 3 collection rates for longer range capability

The perfect scanner for all applications, with programmable data collection rates that enable ranges over 2000 m.⁽²⁾

System Performance

	Polaris LR		
Laser repetition rate (peak and effective, kHz)	50	200	500
Max range capability @90% reflectivity (m)	≥ 2000	750	250
Max range capability @20% reflectivity (m)	976	400	125

(2) More than 2000 m

Range vs Reflectivity

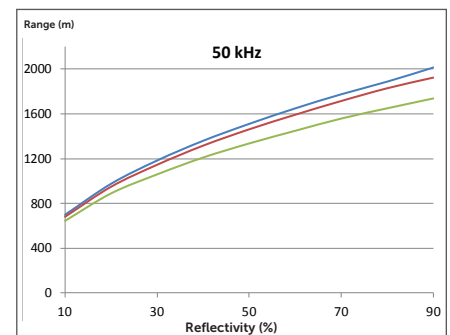
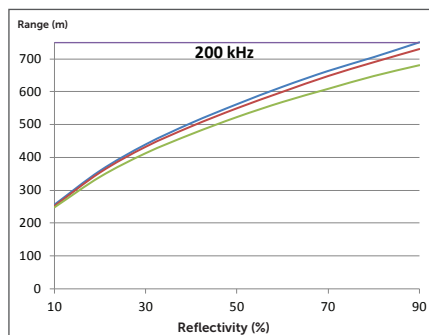
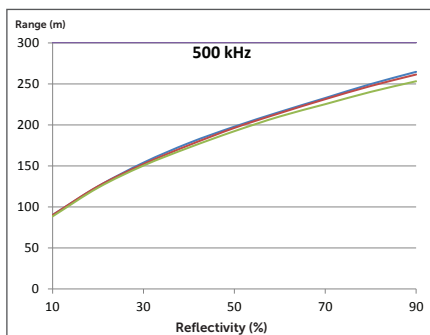

— STD CLR (23 km) — Clear (15 km) — Lt Haze (8 km)



Polaris... Simplified, Touch Screen, Menu-Driven Operation

The Polaris is a stand-alone terrestrial laser scanner that is typically operated via an on-board, sunlight-visible touchscreen. Scans are performed via easy-to-use menu-driven prompts, with data stored locally on the Polaris. After the scan, data is transferred to a Windows-based computer for further processing.

Alternatively, you can operate the Polaris via computer, giving you in-depth control and more visibility into scan parameters. The scan data is then stored on the computer for immediate processing, using project-based software features.

GRAPHICAL USER INTERFACE:

- » Sunlight-visible
- » Resistive single touch
- » 640 x 480 pixels
- » Color TFT LCD

Polaris ATLAScan Data Processing and Workflow

The Polaris software suite, ATLAScan, is a field-proven, PC-based workflow platform that enables easy operation.

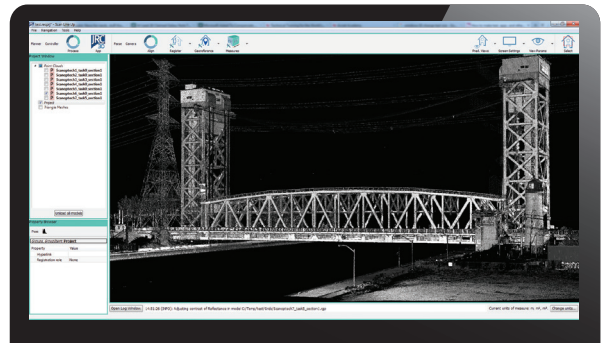

ATLAScan:

- » Manages all data associated with a scan project, including point clouds, imagery, GNSS, referencing control files, and co-ordinate conversions, as well as deliverables such as meshes, models, and line work.
- » Incorporates high-end functionalities like automatic detections of tie points, fitting of primitives, feature line extraction, automatic target-free registration and more...
- » Minimizes processing steps and optimizes functionality to help you shorten your processing times and improve your productivity. ATLAScan also provides tools to view and inspect data, ensuring that your scan coverage is complete and accurate.

ATLAScan's MODULES:

Works	Controls the Polaris scanner, processes and generates geo-referenced point clouds
WorksPro	Provides higher-level deliverables such as feature extraction, meshing, and modeling
Photo	External camera control and integration of imagery onto point clouds
Mobile	Integration with INS system

Specifications

Laser

Range measurement principle	Pulsed
Wavelength [nm]	1550
Laser safety classification ¹	1
Range resolution [mm]	2
Intensity recording [bits]	12
Minimum range [m]	1.5

Scanning Resolution

Angular measurement resolution [μrad]	12
Max. sample density [point to point spacing]	3 mm @ 100 m

Accuracy and Repeatability

Range accuracy 1 sigma	5 mm @ 100 m
Precision single shot	4 mm @ 100 m

Scanning Characteristics

Max. vertical / horizontal field of view [deg]	120 (-45 to +75) / 360
Min. angular step size horizontal [μrad / deg]	30 / 0.0017
Min. angular step size vertical [μrad / deg]	12 / 0.0007

Operation Characteristics

Operating temperature: min. [°C]*	-20
Operating temperature: max. [°C]	+50
Humidity range [%]	95
Control panel built in	Yes
Protection Class	IP64 (Dust and splash proof)

Power

Battery type	Internal or external
Battery power [hr]	2.5
Power supply input voltage	9-32 VDC
Power consumption	60 W

Peripherals

Internal camera	Yes
Export format of internal camera image	JPEG
External camera	Yes [Optional]
Export format of external camera image	JPEG, NEF
User interface	Integrated touchscreen, tablet, PC
Additional sensors	Inclination sensor, L1 GNSS, compass
Registration/orientation methods	L1 GNSS, backsighting, target extraction, resection

Physical Characteristics

Height [mm]	323
Width (diameter) [mm]	217
Total weight [kg]	11.2

¹ Complies with 21 CFR 1040.10 and 1040.11 except for deviations pursuant to Laser Notice No. 50, dated June 24, 2007.

² Max range tested on flat targets, larger than the laser beam diameter, perpendicular angle of incidence and STD Clear visibility (23 km).

* Normal operation to -10°C, extended cold temperature operation to -20°C with Optech Cold Weather package.

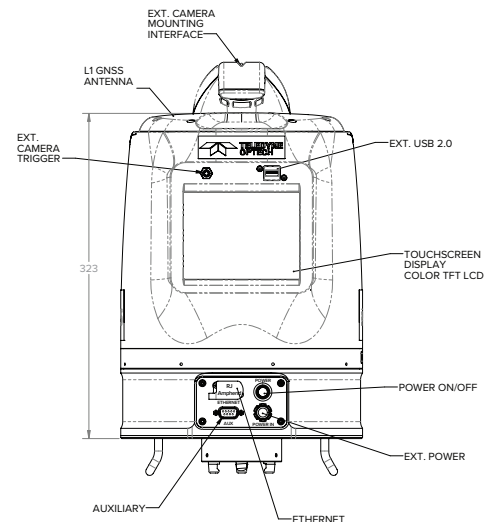
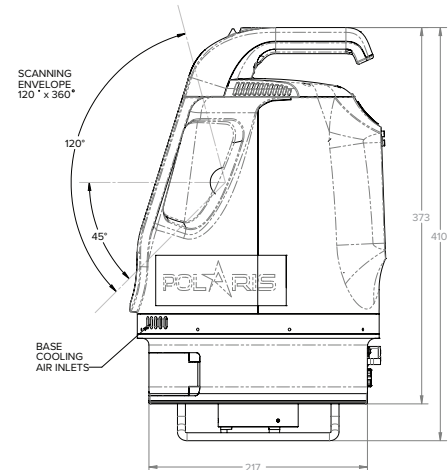
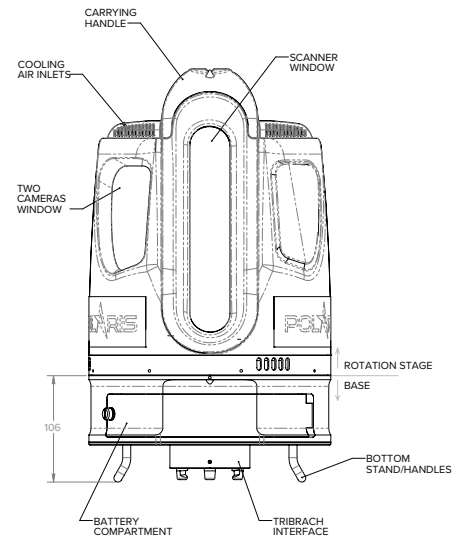

©Teledyne Optech Incorporated. E&OE. Information subject to change without notice.
Printed in Canada. 180111